

SERIES

X2



Gas Fired, Chimney Vented, Cast Iron Water Boiler

- 84% AFUE
- 38 – 280 MBH (8 sizes)
- Advanced controls, accessible inside boiler jacket
 - Integrated boiler control with diagnostics
 - FREE additional pump relay
 - Integral LWCO option requires no piping! (IDL-1200)
- Industry standard tapping locations allow easy, direct replacement for thousands of existing boiler installations
- American-made cast iron heat exchanger
 - Designed to promote turbulent water flow within the section for efficient heat transfer
- A solid, reliable, full-featured boiler at a value price!
- Lifetime limited warranty
- Made in Lancaster, PA, USA

U.S. Boiler Company

X-2: Technical Information



Standard Equipment

- Intelligent Hydronic Control; simple self-diagnostic control system with 3-digit readout for status settings and errors
- Pre-installed IDL-1200 integral LWCO with auto reset (H-model suffix)
- Insulated steel jacket
- Integrated draft diverter, damper and connector included
- Heavy gauge 1" base insulation
- Step-opening redundant gas valve
- Spark ignition with continuous retry
- User-friendly wiring with 120V J-box
- Circulator – choice of Taco or Grundfos
- Cast iron section assembly
- Resettable blocked vent switch
- Boiler drain valve
- Cast iron supply manifold with safety relief valve tapping

X-2 Ratings & Specifications

Model*	Input ¹ (MBH)	DOE Heating Capacity ¹ (MBH)	Net AHRI Rating, Water ^{1,2} (MBH)	AFUE%	Vent Size (Inches)	Approx. Shipping Weight. (lbs.)
X-202	38	32	28	84.0	4	202
X-203	70	59	51	84.0	4	254
X-204	105	88	77	84.0	5	304
X-205	140	117	102	84.0	6	357
X-206	175	146	127	84.0	6	405
X-207	210	176	153	84.0	7	462
X-208	245	205	178	84.0	7	518
X-209	280	234	203	84.0	8	564

* Add suffix "N" for natural gas, or suffix "L" for LP gas models

1. Ratings shown are based on certification up to 2,000 ft. Above 2,000 ft. ratings decrease by 2.5% per 1,000 ft. above sea level. Altitude kits required above 5,400 ft. See altitude conversion kits below.
2. Net AHRI Water Ratings shown based on a piping and pickup allowance of 1.15. Consult manufacturer before selecting boiler for installations having unusual piping and pickup requirements, such as intermittent system operation, extensive piping systems, etc.
3. All X-2 boilers shipped with 30 psi relief valve. MAWP is 50 psi.

X-2 Dimensions & Connections

Model	Width "W" (inches)	Connections (inches)				Water Content (gal.)
		Supply	Return	Gas Valve	Relief Valve	
X-202	14	1-1/4	1-1/4	1/2	3/4	1
X-203	14	1-1/4	1-1/4	1/2	3/4	2
X-204	16	1-1/4	1-1/4	1/2	3/4	3
X-205	19	1-1/4	1-1/4	1/2	3/4	4
X-206	22	1-1/4	1-1/4	1/2	3/4	5
X-207	25	1-1/4	1-1/4	3/4	3/4	6
X-208	28	1-1/4	1-1/4	3/4	3/4	7
X-209	31	1-1/4	1-1/4	3/4	3/4	8

Accessories

- Altitude conversion kit - natural gas (P/N: 112461-01)
- Altitude conversion kit - LP gas (P/N: 112462-01)

NOTES:

Required above 5,400 ft., kits do not convert gas type, X-202 not for use above 5,400 ft.

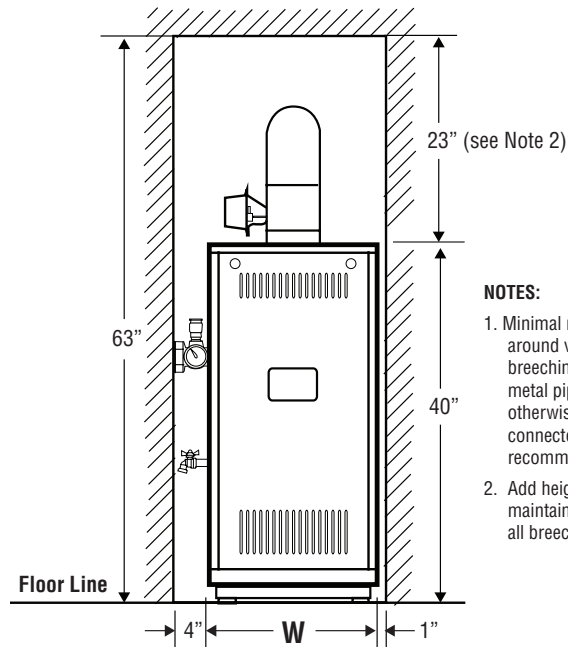
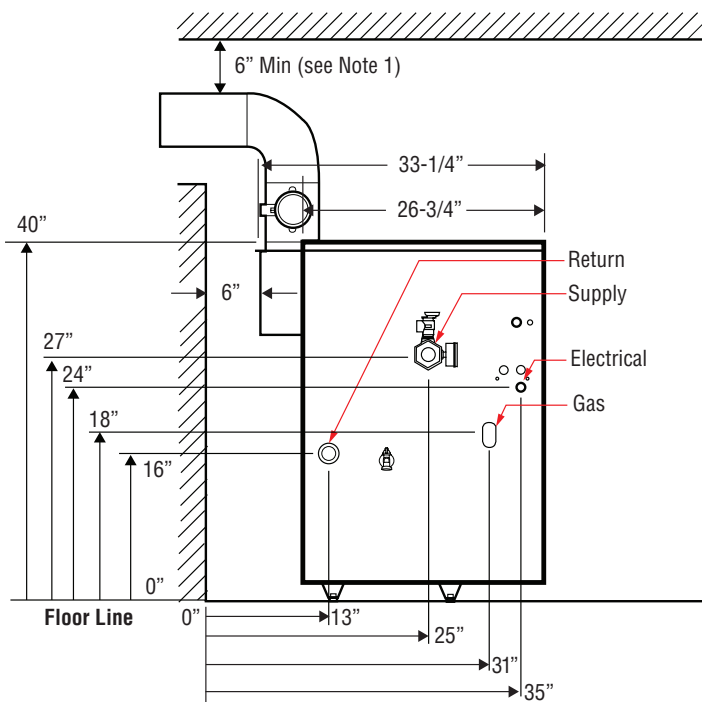

NOTES:

1. Minimal radial distance around vent pipe and breeching for single-wall metal pipe vent connector, otherwise follow vent connector manufacturer's recommended clearances.
2. Add height required to maintain 6" clearance from all breeching components.